

MOOER

VGE 250

Amp Modelling & Multi Effects

Owner's Manual



Contents

PRECAUTIONS	01
Features	02
Top Panel	03-04
Back Panel	05
Home Display	06
Setup	07-12
Play	13
Preset Editing	13-15
Turning on/off effects blocks	14
Value Editing	14
Effects Chain Order	14
Saving	15
TONE CAPTURE	16-17
TUNER	18
RHYTHM	19
LOOPER	20-21
Jam Mode	21
GLB-EQ	22
FX LOOP	23
Expression Pedal	24-28
Calibration	24-25
Volume Pedal	26
Wah Pedal	26
Merge	27-28

CTRL SETTING	29
SYSTEM SETTING	30-35
INPUT LEVEL	31
USB AUDIO	31-32
TAP TEMPO	33
MIDI SETTING	33-34
CAB SIM THRU	34
TRAIL	35
LOOPER MODE	35
SCREEN	36
RESET	36
Effect List	37-49
Specifications	50

PRECAUTIONS

Please read carefully before proceeding

Power Supply

Please connect the designated AC adapter to an AC outlet of the correct voltage. Please be sure to use only an AC adapter which supplies 9V DC, 1A , center negative. Unplug the AC power adapter when not in use or during electrical storms. Please only use the original power supply included with your device.

Connections

Always turn off the power to the GE250 and all adjacent equipment before connecting or disconnecting. This will help prevent malfunction and / or damage to other devices. Also make sure to disconnect all connected cables and the power cord before moving this unit.

Care and Maintenance

Clean only with a soft, dry cloth. If necessary, slightly moisten the cloth. Do not use abrasive cleanser, cleaning alcohol, paint thinners, wax, solvents, cleaning fluids, or chemically-impregnated wiping cloths.

Interference with radios, televisions, and other electrical devices placed nearby may cause reception interference. Operate this unit at a suitable distance from radios and televisions.

Location

To avoid deformation, discoloration, or other serious damage, do not expose this unit to the following conditions:

- Direct sunlight
- Magnetic fields
- Excessively dusty or dirty locations
- Heat sources
- Extreme temperature or humidity
- Moisture
- Strong vibrations or shocks

FCC Certification This device complies with Part 15 of FCC Rules. Operation is subject to the following two conditions:

- This device may not cause harmful interference.
- This device must accept any interference received, including interference that may cause undesired operation.

Features

- 55 high-quality AMP models that utilize MOOER's non-linear digital amp modelling technology. Supports loading extra amp models via computer editor.
- 26 IR-based factory speaker cab models to emulate the same dynamics and feel of a real tube amp.
- 10 user slots to load in your favorite third-party IR files (up to 2048 sample pts).
- 11 different types of effect modules. 152 high-quality effects that cover all the bases from your favorite stompboxes, plugins, and studio rack units.
- TONE CAPTURE function allows you to sample and capture your real-life amplifier to create brand-new digital amp models.
- Store and recall up to 85 banks of presets, each bank with 3 patches for 255 patches total.
- Programmable FX LOOP with optional signal chain routing for easy integration of your favorite effects and ultimate flexibility for 4-cable method and amp setups.
- Stereo outputs (1/4" and XLR) .
- MIDI IN/MIDI OUT
- Global EQ function allows individual EQ setting for main output, headphone output, and XLR balanced output.
- Brand-new RHYTHM module with 60 drum machines and 10 Metronome styles.
- CTRL function supports ON/OFF switch of effect modules, TAP TEMPO function.
- 70 second looper with PRE/POST mode.
- Trail On function for delay & reverb effects.
- Programable built-in expression pedal with support for a second expression pedal.
- Direct, low latency USB audio lets GE250 double up as a digital audio interface and become a "one-stop-shop" solution for recording guitar. Editor software on the computer makes it an all-in-one working station.
- Intuitive and simple UI based on the GE200 user experience makes for fast and easy setup of presets. Spend more time playing and less time scrolling through endless menus.

Top Panel

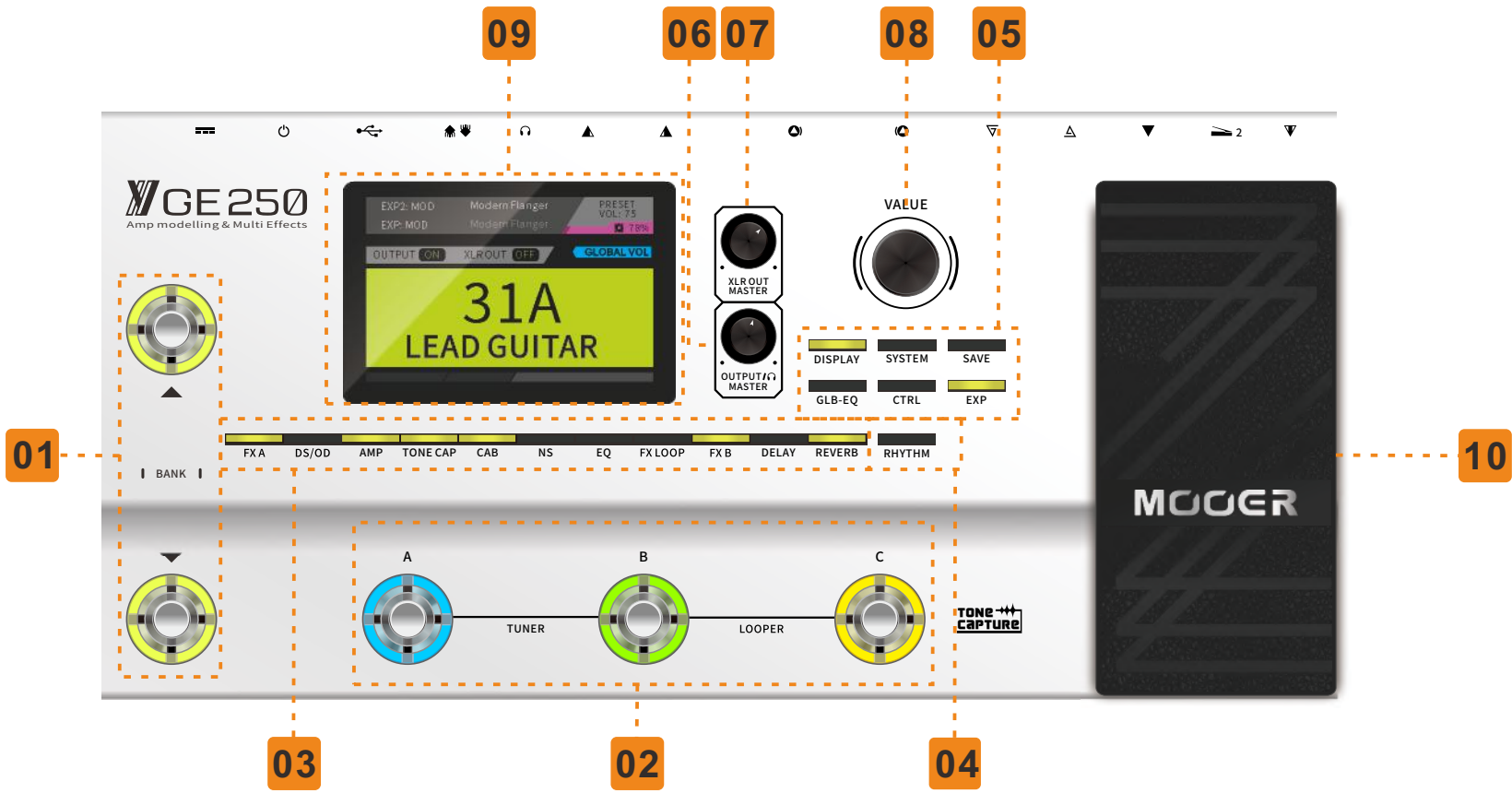

- 01 **BANK UP/BANK DOWN footswitches:** Press to switch between 85 banks.
- 02 **A/B/C Footswitches:** Press to switch between Preset A/B/C.
- 03 **Effects Blocks:** Press to select effects module and enter the edit menu. Press twice to turn off the current module.
- 04 **Rhythm:** Drum Machine/Metronome button. Press to turn on/off drum machine or metronome.
- 05 **Editor Buttons**
 - Display:** Press to enter the Preset/effect chain display page.
 - SYSTEM:** Press to enter system menu.
 - SAVE:** Press to save current setting.
 - GLB-EQ:** Press to enter global EQ settings menu. GLB-EQ supports XLR, 6.35mm (1/4") output and headphone output.
 - CTRL:** Press to enter Control Footswitch menu.
 - EXP:** Press to enter the expression pedal setting menu.
- 06 **OUTOUT/Headphone/🎧 Master:** 6.35mm(1/4") output, headphone output and master volume knob.
- 07 **XLR OUT MASTER:** XLR output level adjust.
- 08 **VALUE:** Editor knob. Navigate and edit different values and parameters.
- 09 **3.5" TFT display screen**
- 10 **Expression pedal:** Built-in expression pedal. Can be set to control wah effect, volume level, or customized values.

Back Panel

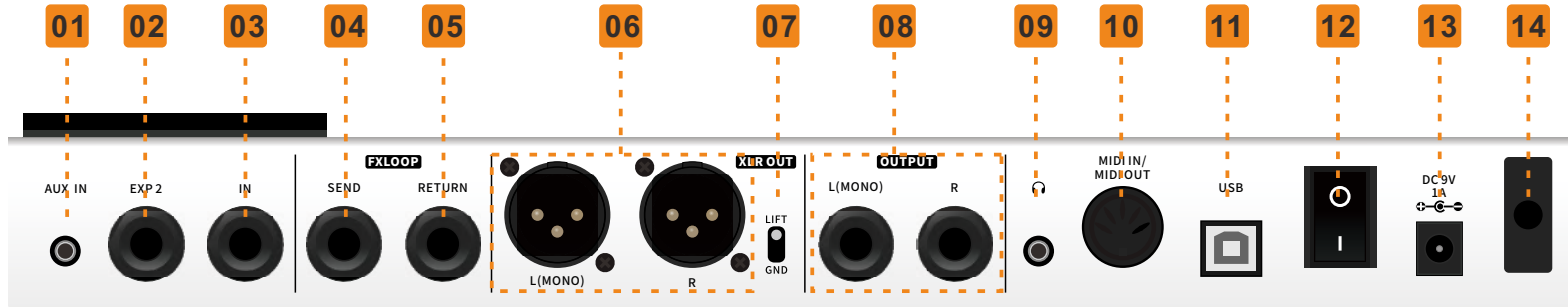

- 01 **AUX IN:** 1/8" stereo jack to connect external media devices for audio playback.
- 02 **EXP2:** 1/4" stereo jack/external expression pedal input.
- 03 **IN:** Instrument input.
1/4" mono jack with Guitar/Line level switch.
- 04 **SEND:** 1/4" FX LOOP. Can connect extra stompboxes, 4-cable method with amplifier.
- 05 **RETURN:** 1/4" FX LOOP. Can connect extra stompboxes, 4-cable method with amplifier.
- 06 **XLR OUT:** XLR balanced output.
- 07 **GND/LIFT switch:** Grounding switch for XLR output.
- 08 **OUTPUT:** 1/4" L/R unbalanced output.
- 09 **PHONES:** Dedicated headphone output. 1/8" stereo jack.
- 10 **MIDI IN / OUT:** MIDI ports for MIDI IN/OUT.
- 11 **USB:** USB Type-B port to connect to direct record digital audio.
Interface with official MOOER software to edit and import/export presets and update firmware.
- 12 **I/O:** Power ON/OFF switch.
- 13 **DC IN:** Connect GE250 power supply.
- 14 **Cable Tidy:** Loop the cable from your power supply to avoid accidental disconnection.

Home Display

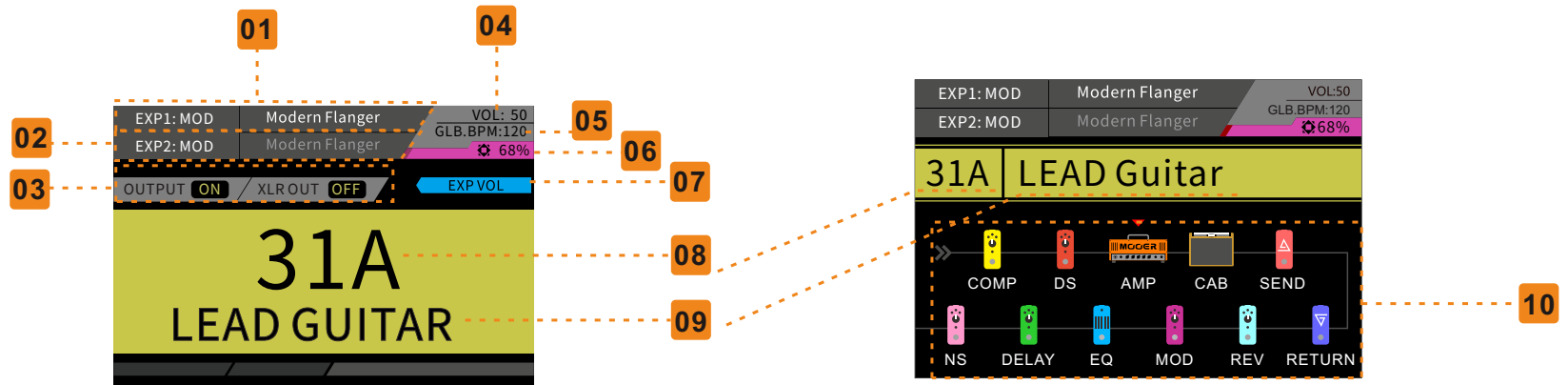

- 01 EXP 1 display
- 02 EXP 2 display
- 03 CAB SIM THRU display
- 04 Preset volume level display
- 05 Preset BPM value
- 06 DSP resource load
- 07 EXP Volume display
- 08 Current preset number
- 09 Current preset name
- 10 Current effects chain

Setup

1. Connecting to FRFR devices

Connect to FRFR (full range, flat response) speaker cabinet, for example, studio monitor, audio interface, stage monitor, PA system or headphones.

It is recommended to turn on the AMP and CAB SIM blocks with FRFR devices.

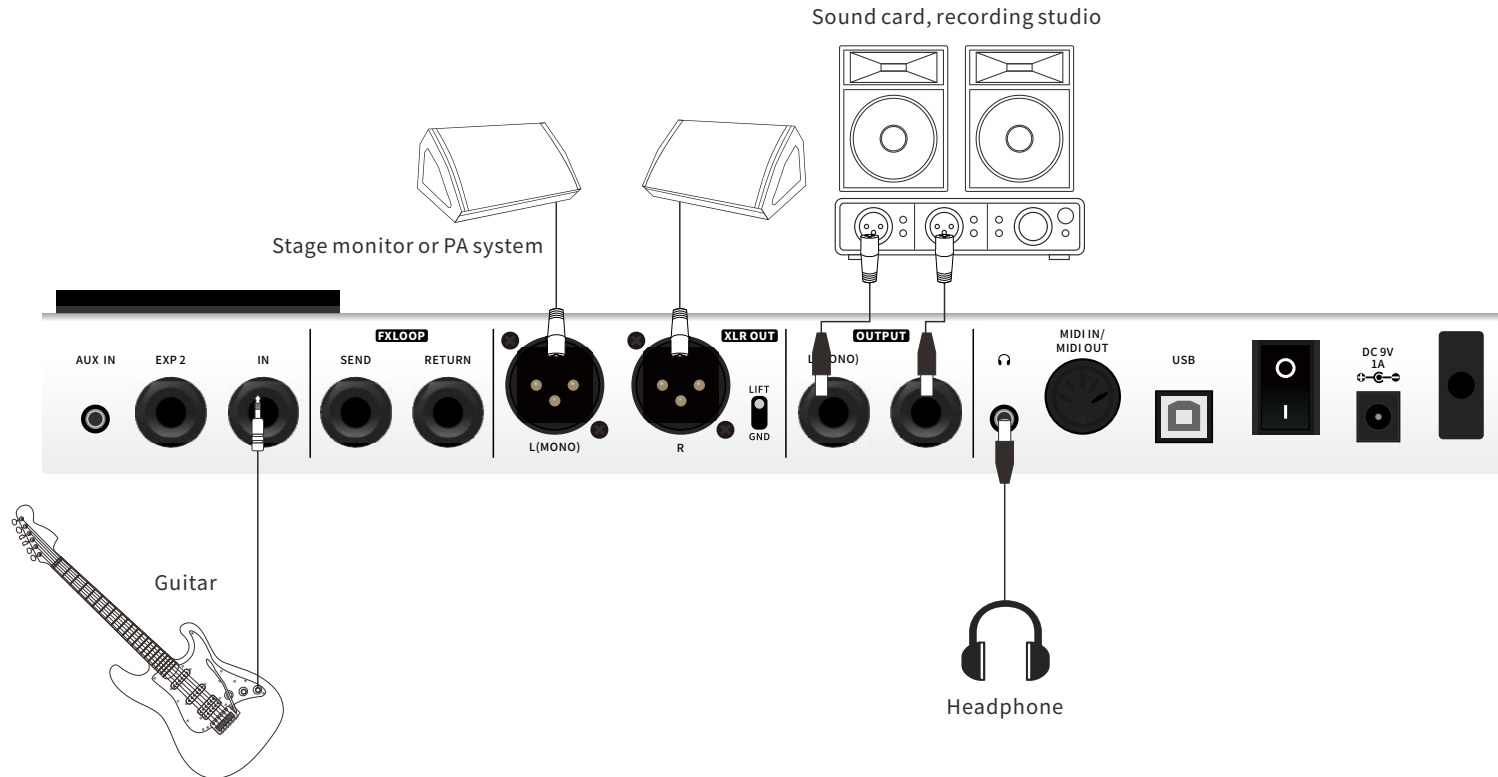

Note: XLR output can prevent signal attenuation and interference from long-distance transfers.

2. Connecting to powered speakers + amplifier

It is recommended to turn on the AMP section when using a guitar speaker cabinet and/or amplifier.

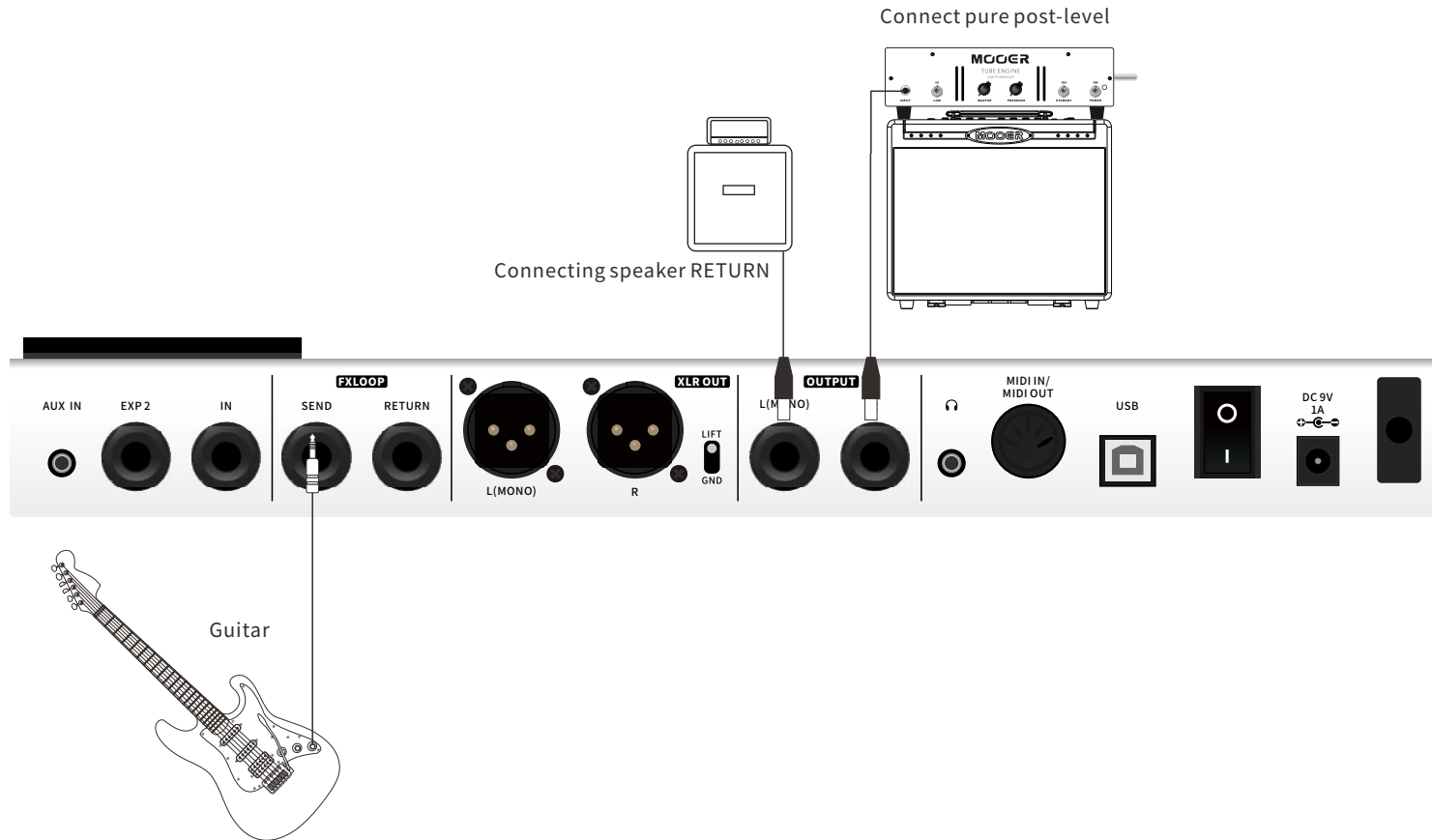

3. Connecting to a FRFR speaker + amplifier

Recommended settings procedure:

- Press SYSTEM button to enter system settings.
- Select CAB SIM THRU setting.
- When connecting to FRFR speaker, set CAB SIM on. When connecting to an amplifier, set CAB SIM to THRU.

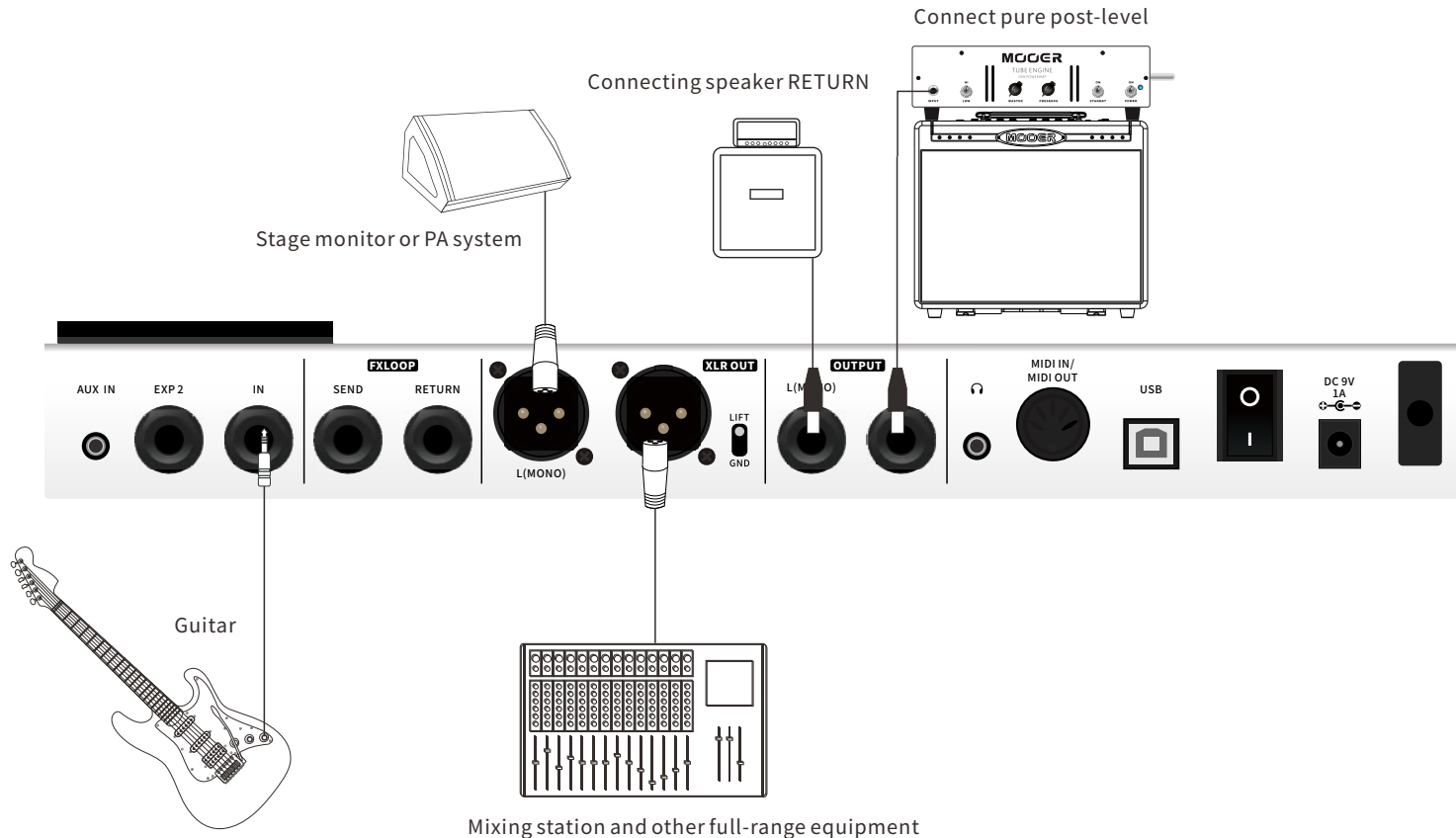

4. 4-Cable Method connection

GE250's FX Loop supports connecting to an amplifier via the 4-cable method. In this setup, the GE250 can play the role of stompboxes in front of the preamp section and effects added after the preamp section. For example, wah, compressor, pre-EQ, pitch shift, and drive might be the pre-stompbox effects while modulation, delay, and reverb are the post-stompbox effects.

Here is the setup procedure:

- Turn on the FX LOOP module. Turn off AMP and CAB modules.
- Set FX LOOP to Serial.
- Press DISPLAY to enter effects chain display. Move the pre-stompbox effects in front of the SEND and move the post-stompbox effects after the RETURN.

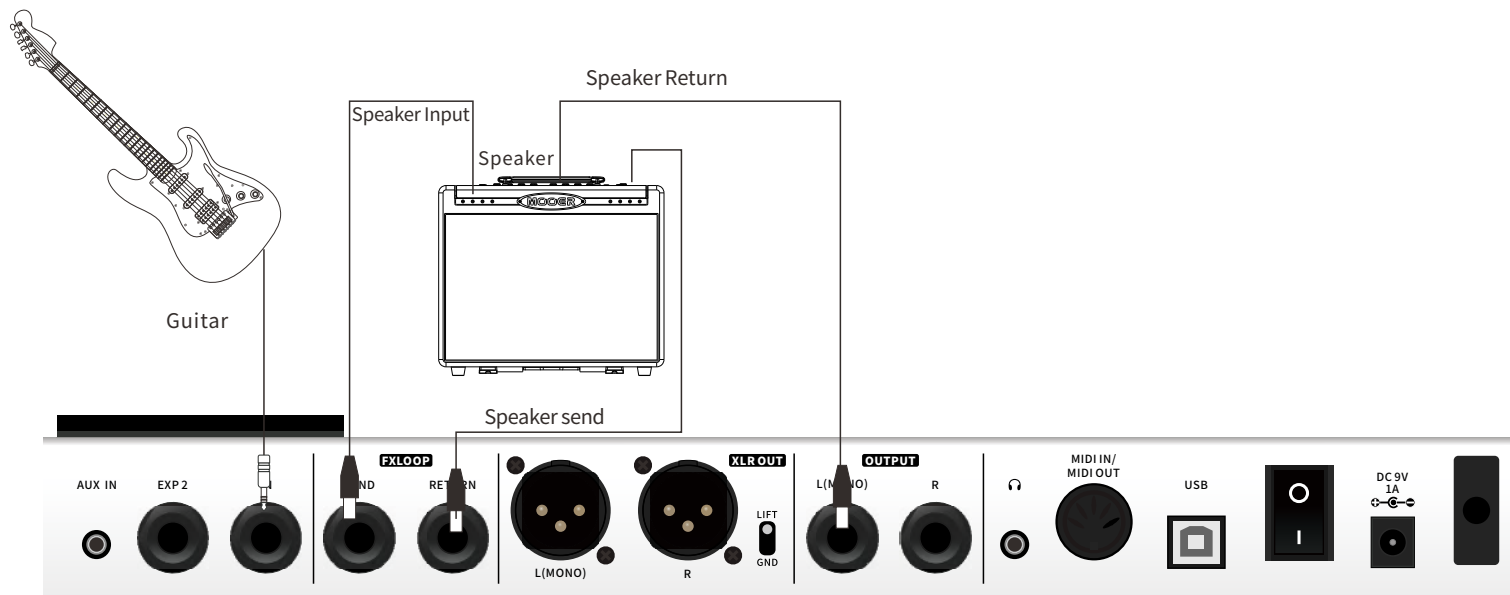

5. Connecting to the INPUT of an amplifier

GE250 plays the role of pre-stompboxes in this setup. It is recommended to turn off the AMP and CAB modules.

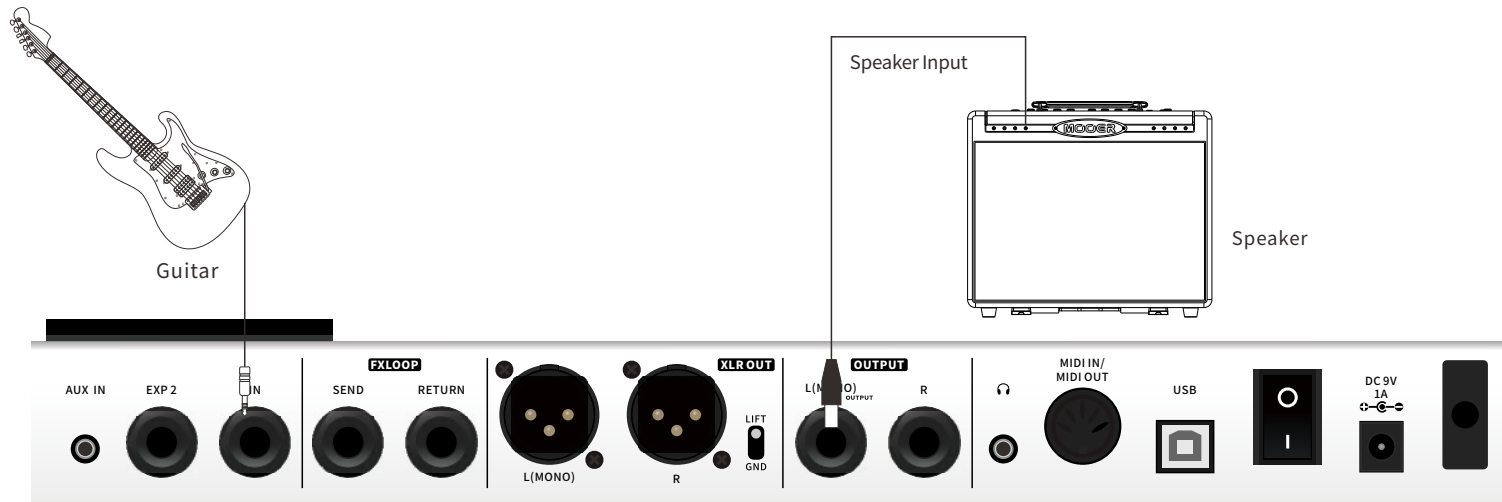

6. Connecting to the FX LOOP of an amplifier

GE250 plays the role of post-stompbox in this setup.

It is recommended to turn off the AMP and CAB modules.

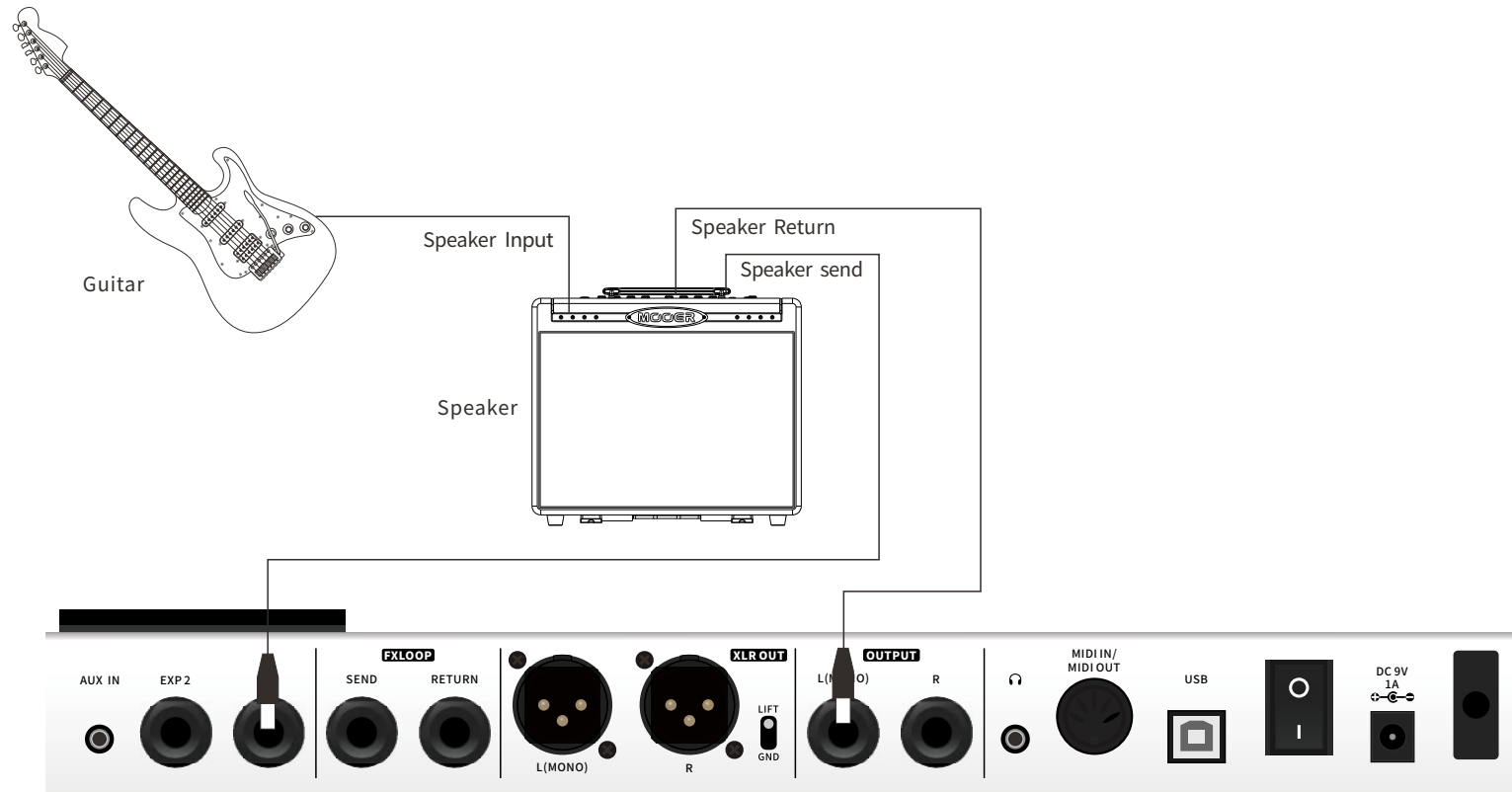

Play

1. Set up the connections depending on your requirements.
2. Rotate the MASTER volume knobs to the minimum value.
3. Plug in the power supply and switch on the GE250.
4. After the GE250 boots up successfully, adjust the MASTER volume level as you desire.

Preset Editing

The GE250 has 10 effects blocks. The order of effects chain, effect type, effect values, effects block on/off, expression pedal, and CTRL footswitch settings can all be saved into preset patches for easy access and sharing. The GE250 has 85 banks. Each bank includes 3 presets for 255 preset patch slots in total.

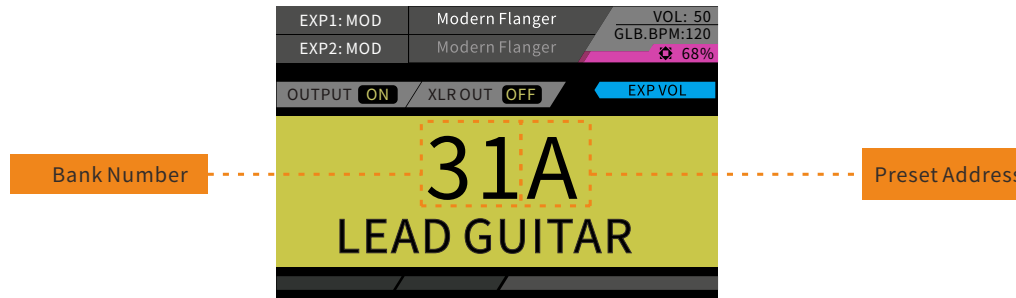

You can switch banks by pressing ▼▲ footswitches. Then press A/B/C to select presets. On the preset page, you can switch between different presets by rotating the VALUE knob.

1. Turn effects blocks on/off

On: When the module is off, press the relevant effects block to turn it on.

Off: When the module is on, press the relevant effect block to enter the effect module. Press twice to turn it off.

The LED light indicates if an effects block is on/off.

2. Detailed Value editing

- Press desired effects block to enter editing menu.
- Use the VALUE knob to select and make a decision.

3. Effects Chain order

GE250 supports adjusting effects chain.

Press the DISPLAY button to enter the effects chain page. When the effects block is on, the effects block icon will display its designated color. When the effects block is off, the effects block icon will be grey.

- Press the DISPLAY button to enter effects chain page.
- Rotate the VALUE to navigate to the desired effect and press VALUE to confirm.
- Rotate VALUE again to place effect in the desired place in the effects chain. Press VALUE again to confirm.

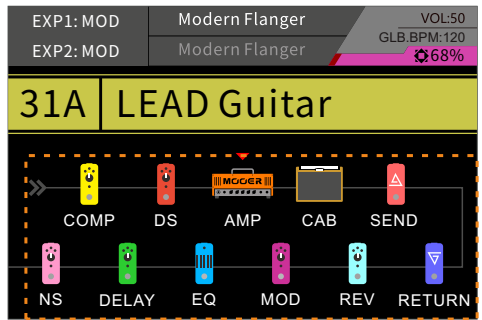

Notice:

1. All the effects blocks will be in default order when set to ON. Users can then edit and save to their desired effects chain order.
2. When the SYSTEM-CAB SIM THRU setting are set to two different settings, the CAB module will be placed at the end of the effects chain.

4. Saving

- Press SAVE to enter save menu.
- Press ▼, ▲ or rotate the VALUE control to select save slot.
- Press VALUE again to edit preset name. Rotate and press VALUE to edit the name.
- Press SAVE again to confirm.

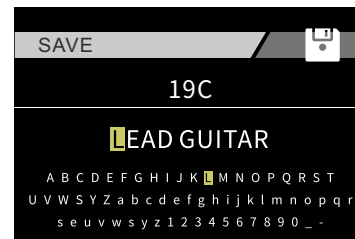

TONE CAPTURE

Tone Capture is an intelligent learning and comparison engine that can be used to create your very own digital models by sampling real-life equipment. With the TONE CAPTURE feature in the GE250, you can capture the tone of any amp.

Before using the TONE CAPTURE feature, please ensure the target amp has a built-in serial FX LOOP.

1. Connect your amp to the GE250 via 4-cable method.
2. Press SYSTEM to enter system settings.
3. Navigate to TONE CAPTURE.
4. Select monitor mode. INTERNAL CAB means the GE250 CAB sim section is on. The FRFR speaker can act as a monitor. EXTERNAL CAB means the CAB sim section is off and the external guitar cabinet is being used as the monitor. Press ▼ footswitch continue.
5. Set the tone of the monitor. Then press ▼ again to continue.

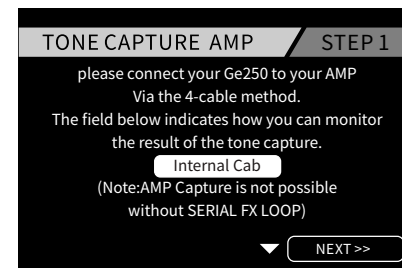
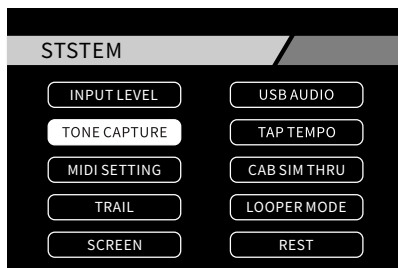
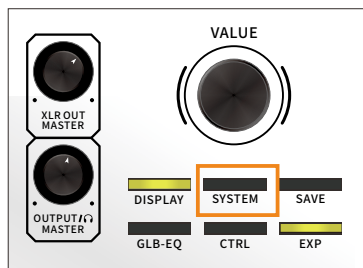

6. Use the VALUE knob to select an amp model. Adjust the GAIN and MST value until the GAIN and MST is close to that of the target amp. Press ▼ footswitch to enter continue.
7. From the TONE CAPTURE sampling page, you can press footswitch A to monitor the target amp or press footswitch B to monitor the GE250's source amp model. Again, ensure the GAIN and MST of the source is roughly the same as that of the target.
8. Press footswitch C to start capturing. You can play whatever you want until the bar loads completely. CAPTURE will turn green after sampling is completed.

Tips: For the best results, we recommend playing the guitar strongly with an open chord first, then playing the full range of the instrument.

9. You can press footswitch A, B, or C to monitor the corresponding tone. If you are not satisfied with the sample, you can press and hold footswitch C to delete current sample then redo STEP 4 again.
10. To save, navigate with VALUE to the . Select a slot for saving. Press SAVE to confirm saving. Then you can press TONE CAPTURE button to activate the sample.

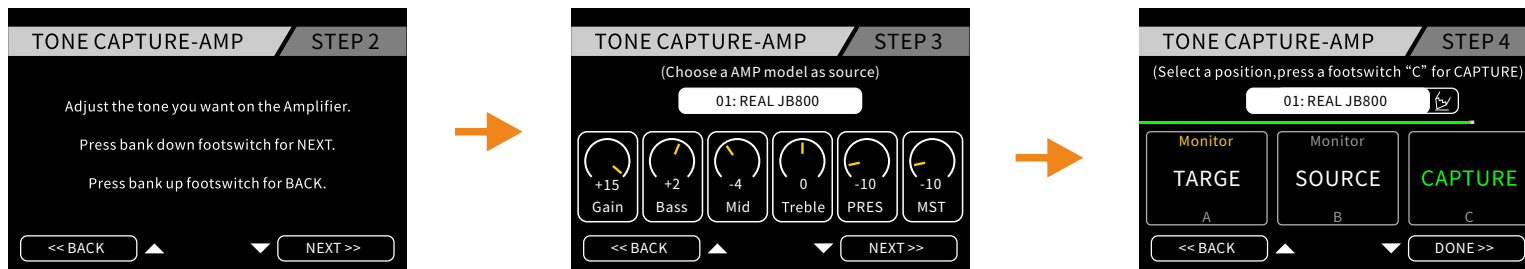

Notice: The TONE CAPTURE block has a SYNC option. When it is on, the amp model will be recalled as the SOURCE setting when sampling. Otherwise, the amp model will based on the current patch.

TUNER

Press footswitch A and B simultaneously to start the TUNER.

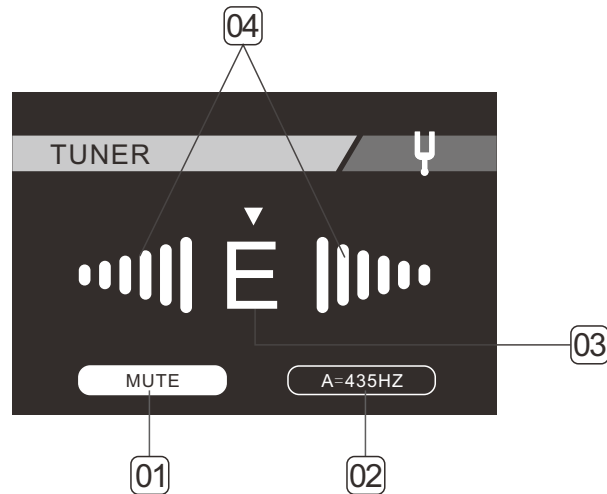

1. MUTE/BYPASS the audio signal.
2. Tuner calibration.
3. Nearest note.
4. Display is red when the note is flat or sharp.
Display is green when the note has achieved the correct pitch.

RHYTHM

GE250 has a built-in RHYTHM module with 60 drum machines and 10 Metronome settings for you to use when practicing. Press the RHYTHM button to toggle this module on/off and enter it's edit screen.

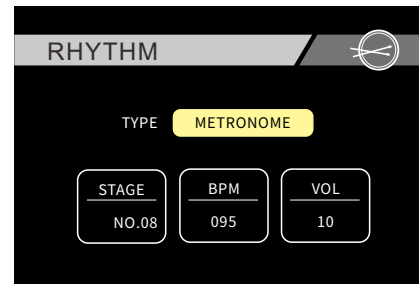
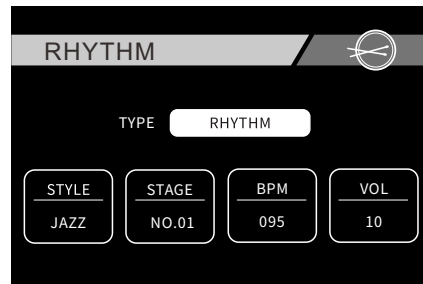

TYPE: Select between RHYTHM (drum machine) or METRONOME.

STYLE: Select pattern style.

BPM: Adjust the RHYTHM speed.

VOL: Adjust the RHYTHM playback volume.

CTRL/TAP footswitch can be used to tap the tempo of the drum machine.

LOOPER

GE250 has an integrated 150-second looper complete with special effects.
Press the footswitch B and C simultaneously to access the looper screen.

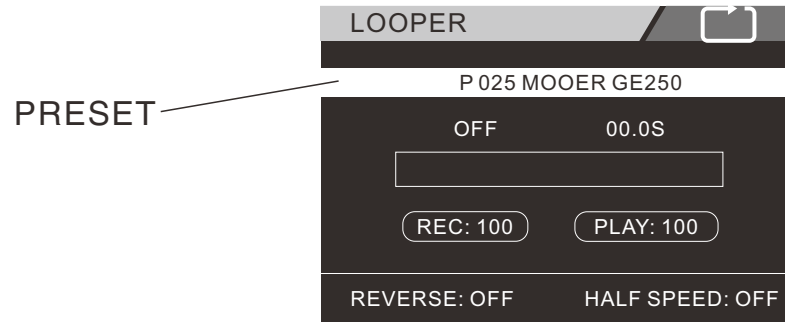

You can use the VALUE control to adjust the following parameters:

PLAY: Playback volume of the looper.

REC: Recording level of the looper.

PRESET: Current Preset.

Notice: The memory of looper will be cleared after power off.

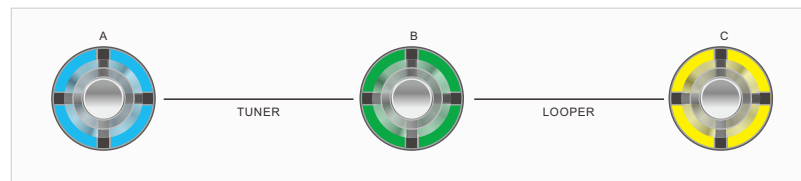

Use footswitch A, B, C to control the looper.

A: Press to toggle REVERSE effect on/off.

B: Press to toggle HALF SPEED on/off.

- C:**
- Press once to begin recording, playback, and overdub.
 - Double press to stop.
 - Press and hold to clear the current loop from memory.

Jam Mode

GE250 has Jam Mode, allows users to turn on drum machine and looper simultaneously for play.

Below is the procedure for setup of Jam Mode:

1. Press RHYTHM button, activate drum machine.
2. Enter LOOPER, start with REC. Drum Machine will automatically restart from the beginning.
3. Press to start PLAY when a bar of drum machine is about to finish, then the looper will start automatically when next bar begins.
4. You can press STOP to stop Jam mode. If you restart to play, the recorded track and the drum machine will still start simultaneously.

Notice:

1. Jam mode cannot use the 1/2 SPEED or REVERSE effects.
2. User need to turn on RHYTHM first, then the LOOPER.
3. During the Jam mode, neither the speed nor rhythm type of the RHYTHM can be changed.

Justify

In Jam mode, MOOER add the rhythm justify function.

1. If user finishes recording with PLAY, and the end of track is less than half of current bar of drum machine, the looper will delete the recording of the last bar and playback immediately.
2. If user finished recording with PLAY, and the end of the track is more than half of the current bar of drum machine, the looper will keep recording till the end of bar instead of playback immediately.



GLB-EQ

GLB-EQ is for the main output, headphone output, and the XLR output.

Press GLB-EQ to access GLOBAL EQ screen.

Navigate with VALUE to select output.

Press VALUE to toggle on/off.

When the GLB-EQ is activated, the GLB-EQ LED button will light up.



FX LOOP

GE250 has a built-in FX LOOP for connecting to extra effects and utilizing the 4-cable method.

Press FX LOOP to enter FX LOOP screen. The SEND, RETURN are listed in the effects chain. You can adjust the order as you desire.

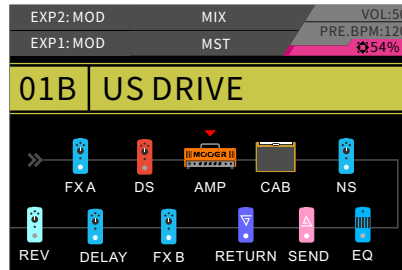

LOOP MODE: Set to Serial or Parrallel mode.

DRY/WET: Set the rate of dry/wet of the parrallel FX LOOP.

RETURN LEVEL: The input level of RETURN. The default value is 0dB.

SEND LEVEL: The output level of SEND. The default value is 0dB.

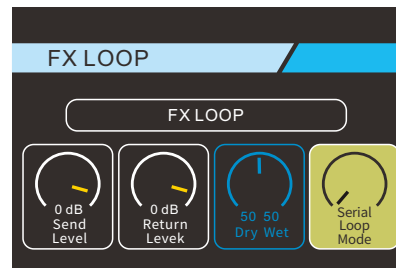

Notice: The RETURN cannot be set in front of SEND.

Expression Pedal

The GE250 features a built-in expression pedal (EXP) as well as support for a second external expression pedal (EXP2). To use an external expression pedal with the GE250, connect it to the EXP2 input using a TRS stereo jack cable. Both expression pedals can be calibrated and setup in the EXP menu.

Notice: It is recommended to calibrate the expression pedal before using the GE250 for the first time.

Calibration

- Set the pedal in the heel-down position and press the VALUE control to confirm.



- Set the pedal to the toe-down position and press the VALUE control to confirm.



- Set the pedal in the toe-down position and apply forward pressure. While applying forward pressure, press the VALUE control to confirm. This will set the sensitivity of the EXP pedal toe-down activation switch.

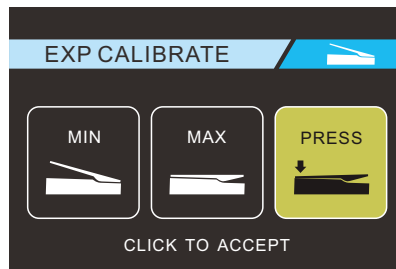

Volume Pedal

Pre-Volume

- Select EXP or EXP2 from the EXP menu.
- Select FUNCTION. Set the relevant control value. e.g. Level of FX A/B, Volume of OD/DS, MST (master) of AMP module.
- Press expression pedal to activate.

Global Volume

- Select EXP VOL in the EXP menu.
- Set the EXP1 as the EXP VOL PEDAL with the VALUE knob.
- Press the expression pedal to activate.
- The MIN/MAX level of volume can be edited by the user.

Wah Pedal

- Select EXPA/EXP2 in EXP Menu, then choose FUNCTION.
- Select the FXA—Position. Press DISPLAY to exit.
- Select FXA block, choose CRY WAH or 535WAH as the wah pedal.
- Press expression pedal toe-down switch to activate it.

Tips: You can define the expression pedal to control any value of the effects in the function menu such as AMP master volume, the gain of the OD/DS, etc.



Merge

MERGE is a special function which allows you to control multiple parameters from any effects blocks and set the parameter value end points for both heel-down and toe-down positions. This can be used in many ways, but it's very good for blending seamlessly between two different sounds or having advanced control over special effects.

In this example, we will show you how to control DELAY time, feedback, and level simultaneously with the EXP pedal by using the MERGE function. Activate the EXP pedal and set it in the heel-down position after assigning the MERGE function from the EXP settings menu. You must set up each parameter value one at a time.



(Heel down)

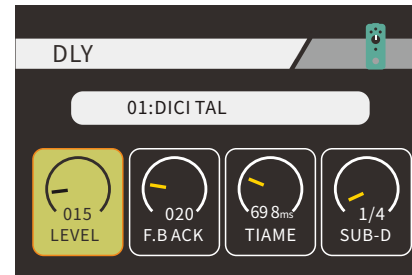

- Open the DELAY effects block by pressing the DELAY button.
- Set the EXP pedal in the heel-down position.
- Select the LEVEL parameter to a value of 15. Do not press the VALUE control again yet.



(Heel down)

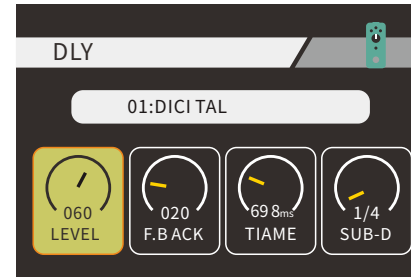

- Set the EXP pedal to the toe-down position.
- Change the LEVEL parameter value to 60. (The box surrounding LEVEL will change color).
- You can now control the LEVEL between these two set value points using the EXP pedal. Press the VALUE control to confirm and prepare to assign your next parameter.

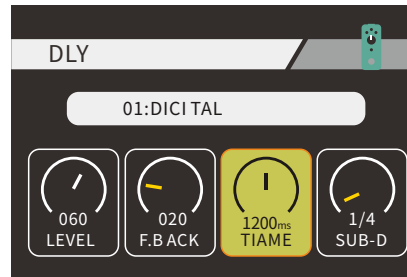

Repeat steps 1 and 2 for the F.BACK with a value of 50 in the heel-down position and 10 in the toe-down position. Repeat steps 1 and 2 for the TIME with a value of 300ms in the heel-down position and 1200ms in the toe-down position.

Now try moving the EXP Pedal back and forth and you will see how all of the assigned parameters simultaneously move between their set end points. HAVE FUN!!!

Notice:

- 1. If the expression pedal is not working normally, try to recalibrate it.**
- 2. EXP and EXP2 can be set separately in MERGE.**

CTRL SETTING

The CTRL SETTING has 3 main functions:

NA: Press to disable the CTRL footswitch.

ON/OFF: Toggle assigned effects blocks on/off.

TAP: Tap the footswitch multiple times to control the tempo of your delay.

To switch between ON/OFF and TAP, press and hold the current patch footswitch for one second.

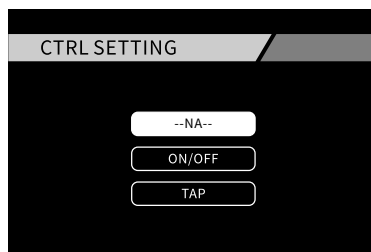

- Select TAP to make the default function of the CTRL/TAP footswitch “TAP TEMPO” within the preset.
- Select ON/OFF to assign effects blocks to be switched on/off using the current patch footswitch.

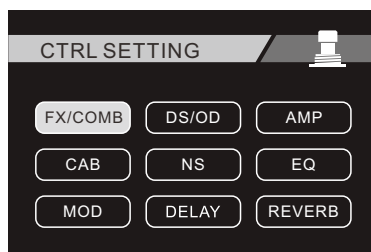

Use the VALUE control to highlight and select which effects blocks you wish to assign to be switchable using the CTRL footswitch.

The CTRL footswitch will change color between BLUE and PURPLE to indicate the ON/OFF of effects blocks.

SYSTEM SETTING

Enter the system settings menu using the SYSTEM button. In this menu you will find various global settings which can be used to setup your GE250.

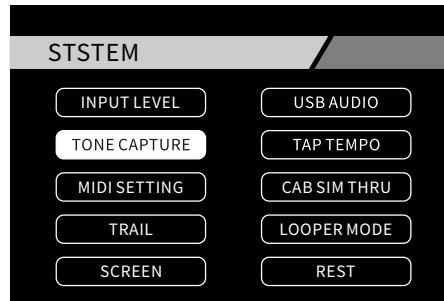

INPUT LEVEL: Adjust the INPUT gain level.

USB AUDIO: Configure the USB AUDIO outputs.

TONE CAPTURE: Refer to TONE CAPTURE section.

TAP TEMPO: Global/preset tap tempo setting.

MIDI SETTING: MIDI mapping.

CAB SIM THRU: Assign CAB simulation to outputs.

TRAIL: Trail on/off function.

LOOPER MODE: PRE/POST-Looper setting.

FS MODE: Change the FOOTSWITCH MODE.

SCREEN: Adjust the brightness level of the display screen.

RESET: Reset GE250 to factory settings and view current system firmware version.

INPUT LEVEL

You can adjust the input level according to your instrument. Ranges from $-\infty$ ~+6dB.

USB AUDIO

GE250 supports 24bits 44.1kHz USB direct recording.

Windows users may need to download and install the ASIO driver to use with the GE250. Please enter the MOOER official website (www.moeraudio.com) to download it. MAC users do not need to download this driver.

1. AUDIO MODE

NORMAL: Normal recording mode. GE250 plays the role of audio interface.

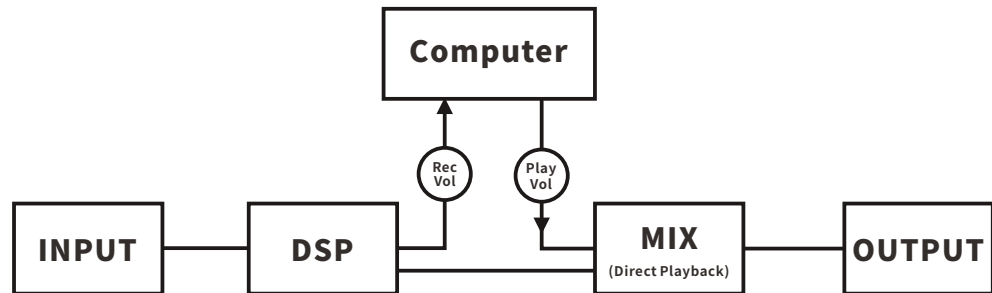
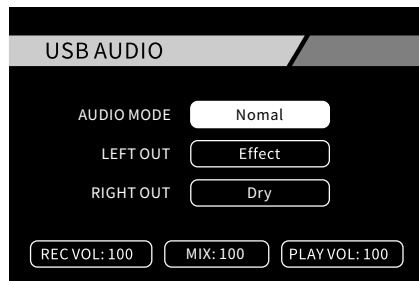

REAMP: The signal will go through to computer, then feed to the effects chain of GE250.

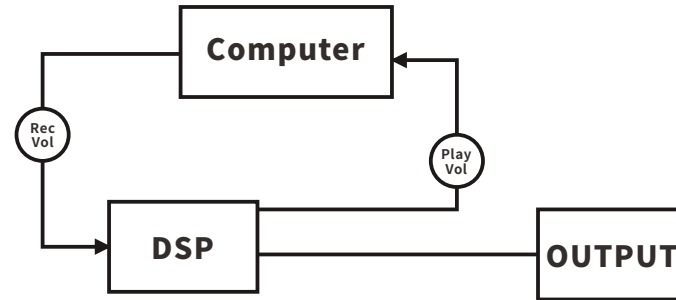
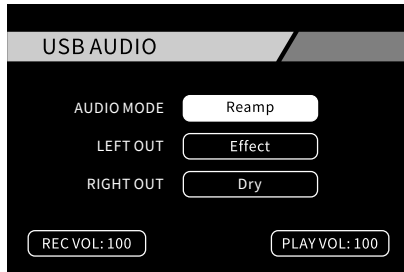

2. LEFT OUT/RIGHT OUT

DRY: Outputs your unaltered instrument signal and bypasses the signal processing.

EFFECT: Outputs the fully processed signal from the GE250.

REC VOL: Adjusts the level of the digital audio sent to your computer.

PLAY VOL: Adjusts the level of the monitor (playback) volume of the GE250.

MIX: The rate of main output and the USB output. MIX=0 indicates pure main output, USB output will be mute. MIX=100 indicates pure USB output, the main output will be mute.

TAP TEMPO

Tap tempo function can be set to GLOBAL and PRESET.

GLOBAL: The BPM of tap tempo for all presets.

PRESET: The BPM of tap tempo for current preset.

MIDI SETTING

GE250 can be set to MIDI IN or MIDI OUT. The detailed MIDI mapping setting can be set in the MIDI SETTING menu.

1. MIDI IN

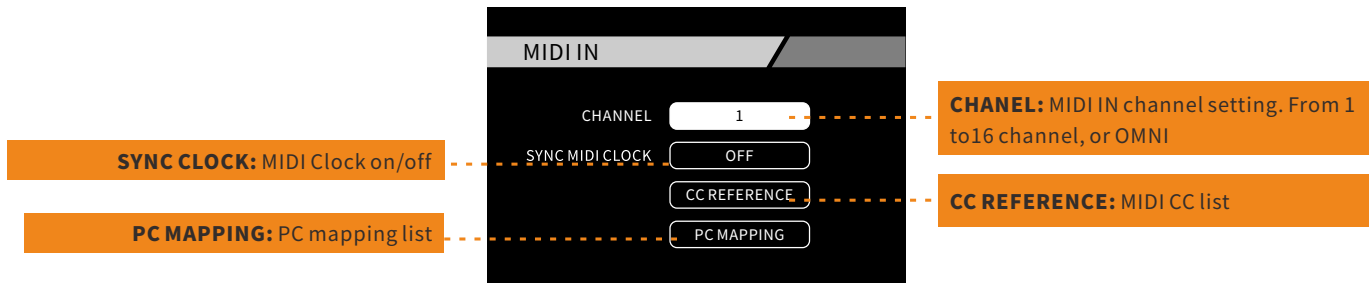

2. MIDI OUT

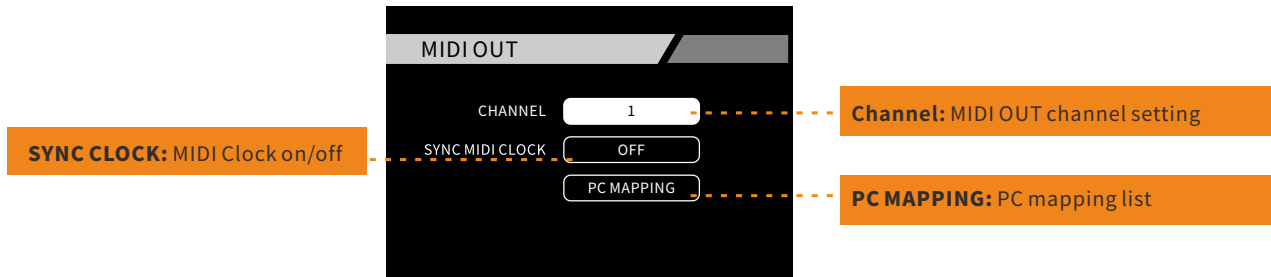

CAB SIM THRU

The speaker cabinet simulation in the GE250 can be configured to affect various output combinations.

This can be useful in various situations.

For example, you may wish to connect the LEFT output of the GE250 to your on-stage amplifier with CAB SIM disabled, while connecting the RIGHT output of GE250 direct to the PA system with the CAB SIM enabled.

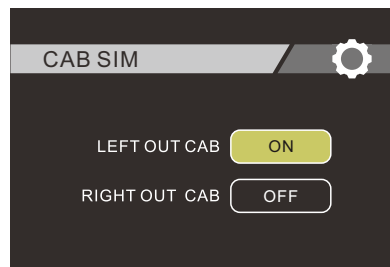

ON: The CAB SIM is enabled for this output.

THRU: The CAB SIM is disabled for this output.

TRAIL

Trail On function allows the trail of delay/reverb effects to continue for a few seconds after the delay/reverb effects are turned off.

1. When using CTRL to turn off the delay/reverb effects, the trail will continue for a few seconds after it has been turned off.
2. When switching between different presets, the trail will continue for a few seconds after switching.

LOOPER MODE

LOOPER POSITION

The signal chain is shown below:



PRE: The LOOPER will be placed in front of the effects chain in order to record the dry signal directly from your guitar. In PRE mode, the effects chain can be fed by the recorded track and you can adjust the effects chain in real time to get different output tracks.

POST: The LOOPER will be placed at the end of the effects chain in order to record the wet signal as the output from the GE250. In POST mode, the looper works as a traditional one does. Once the track is recorded, it cannot be affected by effects from the GE250.

SCREEN

The brightness of the screen can be set in this menu.

RESET

From here you can view the current firmware version of the GE250. Select YES to reset your GE250 to factory settings.

Effect List

FXA & FXB		
MODEL NAME		Description
1	CRY WAH	Based on DUNLOP® GCB95
2	535 WAH	Based on DUNLOP® Crybaby 535Q
3	AUTO WAH	Based on MOOER® @WAH
4	TALK WAH AH	Based on MOOER® RedKid Talk wah
5	TALK WAH OH	Based on MOOER® RedKid Talk wah
6	TOUCH WAH	Based on MOOER® Envelope
7	YELLOW COMP	Based on MOOER® YELLOW COMP
8	BLUE COMP	Based on MOOER® BLUE COMP
9	PHASERS	Sin wave phaser
10	TEP PHASER	Square wave phaser
11	FAT PHASER	Bass frequency phaser
12	FLANGER	Standard flanger
13	JET-FLANGER	Jet like flanger
14	TREMOLO	Standard Tremolo
15	STUTTER	Square wave flanger
16	VIBRATO	Treble flanger
17	DETUNE	Pitch shift flanger
18	ROTARY	Rotary effect
19	ANA-CHORUS	Chorus
20	RING MOD	Ring like modulation

FXA & FXB

MODEL NAME		Description
21	Q-FILTER	Filter modulation
22	HIGH PASS	High pass modulation
23	LOW PASS	Low pass modulation
24	SLOW GEAR	Slow attack effect
25	LOFI	Low bit effect
26	DIGITAL DELAY	Digital delay
27	INTEL REDUCER	Noise gate in front of drive
28	NOISE GATE	Noise gate after the drive
29	POLY PITCH	Poly pitch shifter
30	TRI-CHORUS	Tribble chorus
31	MONO PITCH	Mono pitch shifter
32	ANALOG DELAY	Analog delay
33	NOISE KILLER	Standard noise killer

Parameter	Explanation
Q	The Q or “Quality factor” is the ratio of the resonant frequency to the bandwidth between the upper and lower -3dB frequencies. In this particular application, you can think of the Q as the shape of your band pass filter. A low Q will have a wider, rounder shape and sound less pronounced. A high Q will have a narrower, sharper shape and sound more pronounced
Position	The position of the wah in it's pedal sweep. 0 is equal to heel down, 100 is equal to toe down
	*Notes: If you want to use the EXP pedal to control the wah sweep, assign “WAH > Position” as the function in the EXP menu. You can also turn on 'Toeswitch' function to turn on/off the wah module while you are pressing the EXP pedal
PEAK	Centre frequency volume level
Level	Volume level
Rate	Speed of the position sweep LFO
Range	Range of the position sweep
Attack	Speed of the envelope. 100 is the fastest
Sens	Sensitivity of the envelope
Threshold	The threshold control sets the level at which the compression effect is engaged
Ratio	The amount of attenuation to be applied to the signal
Depth	Adjusts the depth of modulation
Mix	Sets the proportion of mix between the original (dry) and 'effected' (wet) signals. 0 is total dry signal, 100 is total wet signal
Feedback	Adjusts the volume that is returned to the input. Higher settings will result in more delay repeats
Tone	Adjusts the tone of modulation
Pitch	Set the pitch shift value (Detune : 100 cents = 1 semitone = 1 half-step)
Rise	The attack of slow gear
Sample	Adjusts the sample rate of Lofi effect
(Lofi)	
Bit	Adjusts the bit rate of Lofi effect
(Lofi)	

DS/OD

MODEL NAME		Description
1	TUBE DR	Based on B.K. Butler® Tubedrive
2	808	Based on IBANEZ® TS808
3	PURE BOOST	Based on MOOER® PURE BOOST
4	FLEX BOOST	Based on MOOER® FLEX BOOST
5	DDRIVE	Based on BARBER® Direct Drive
6	BLACKRAT	Based on ProCo® Rat
7	GREY FAZE	Based on Dunlop® Fuzz Face
8	MUFFY	Based on EHX® Big Muff
9	MTL ZONE	Based on BOSS® METAL ZONE
10	MTL MASTER	Based on Digitech® METAL MASTER
11	OBSESSIVE DIST	Based on Fulltone® OCD
12	JIMMY OD	Based on Paul Cochrane® Timmy OD
13	FULL DRV	Based on Fulltone® Fulldrive 2
14	SHRED	Based on Marshall® Shred master
15	BEEBEE PRE	Based on Xotic® BB Preamp
16	BEEBEE+	Based on Xotic® BB Plus
17	RIET	Based on Suhr® Riot
18	TIGHT DS	Based on Amptweaker®
19	FULL DS	Based on Fulltone® GT-500
20	GOLD CLON	Based on Klon® Centaur gold
21	VX TUBE OD	Based on VOX® Tube Od
22	TIGHT METAL	Based on Amptweaker® TightMetal
23	THE JUICER	Based on MOOER® The Juicer
24	RUMBLE DRIVE	Based on MOOER® Rumble Drive

DS/OD

MODEL NAME		Description
25	SOLO	Based on MOOER® Solo
26	BLUES MOOD	Based on MOOER® Blues Mood
27	BLUES CRAB	Based on MOOER® Blues Crab
28	HUSTLE DRIVE	Based on MOOER® Hustle Drive

Parameter	Explanation
Volume	Volume level control
Tone	Tone control
Gain	Gain level control

AMP MODELS

MODEL NAME		Description
1	65 US DX	Based on Fender® 65 Deluxe reverb preamp section
2	65 US TW	Based on Fender® 65 Twin Reverb preamp section
3	59 US BASS	Based on Fender® 59 Bassman preamp section
4	US SONIC	Based on Fender® Super Sonic preamp section
5	US BLUES CL	Based on Fender® Blues Deluxe preamp section Clean Channel
6	US BLUES OD	Based on Fender® Blues Deluxe preamp section Drive Channel
7	J800	Based on Marshall® JCM800 preamp section
8	J900	Based on Marshall® JCM900 preamp section
9	PLX100	Based on Marshall® Plexi 100 preamp section
10	E650 CL	Based on ENGL® E650 Clean Channel
11	E650 DS	Based on ENGL® E650 Distortion Channel
12	POWERBELL CL	Based on ENGL® E645 Clean Channel
13	POWERBELL DS	Based on ENGL® E645 Distortion Channel
14	BLACKNIGHT CL	Based on ENGL® E650 Blackmore Clean Channel
15	BLACKNIGHT DS	Based on ENGL® E650 Blackmore Distortion Channel
16	MARKIII CL	Based on MESA/Boogie® MARK III Clean Channel
17	MARKIII DS	Based on MESA/Boogie® MARK III Distortion Channel
18	MARKV CL	Based on MESA/Boogie® MARK V Clean Channel
19	MARKV DS	Based on MESA/Boogie® MARK V Distortion Channel
20	TRI REC CL	Based on MESA/Boogie® Triple Rectifier Clean Channel
21	TRI REC DS	Based on MESA/Boogie® Triple Rectifier Distortion Channel
22	ROCK VERB CL	Based on Orange® Rockerverb Clean Channel
23	ROCK VERB DS	Based on Orange® Rockerverb Distortion Channel
24	CITRUS 30	Based on Orange® AD 30 preamp section
25	CITRUS 50	Based on Orange® OR 50 preamp section

AMP MODELS

MODEL NAME		Description
26	SLOW 100 CR	Based on Soldano® SLO-100 Crunch Channel
27	SLOW 100 DS	Based on Soldano® SLO-100 Distortion Channel
28	DR.ZEE 18 JR	Based on DR.Z® Maz18 Jr preamp section
29	DR.ZEE 18 RECK	Based on DR.Z® Z-Wreck preamp section
30	JET 100H CL	Based on Jet City® JCA100H Clean Channel
31	JET 100H OD	Based on Jet City® JCA100H Drive Channel
32	JAZZ 120	Based on Roland® JC-120 preamp section
33	UK30 CL	Based on Vox® AC30 Clean Channel
34	UK30 OD	Based on Vox® AC30 Drive Channel
35	HWT 103	Based on Hiwatt® DR-103 preamp section
36	PV 5050 CL	Based on Peavey® 5150 Clean Channel
37	PV 5050 DS	Based on Peavey® 5150 Distortion Channel
38	REGAL TONE CL	Based on Tone King® Falcon Rhythm Channel
39	REGAL TONE OD1	Based on Tone King® Falcon Tweed Channel
40	REGAL TONE OD2	Based on Tone King® Falcon Lead Channel
41	CAROL CL	Based on Two Rock® Coral Clean Channel
42	CAROL OD	Based on Two Rock® Coral Drive Channel
43	CARDEFF	Based on Two Rock® Cardiff preamp section
44	EV 5050 CL	Based on EVH® 5150 Clean Channel
45	EV 5050 DS	Based on EVH® 5150 Distortion Channel
46	HT CLUB CL	Based on Blackstar® HT Stage 100 Clean Channel
47	HT CLUB DS	Based on Blackstar® HT Stage 100 Distortion Channel
48	HUGEN CL	Based on Diezel® Hagen Clean Channel
49	HUGEN OD	Based on Diezel® Hagen Drive Channel
50	HUGEN DS	Based on Diezel® Hagen Distortion Channel

AMP MODELS

MODEL NAME		Description
51	KOCHE OD	Based on Koch® Powertone Drive Channel
52	KOCHE DS	Based on Koch® Powertone Distortion Channel
53	US GOLD 100	Based on Friedman® Be100 Clean Channel
54	CLUS GOLD 100 DS	Based on Friedman® Be100 Distortion Channel
55	CALI JP A	Based on Mesa Boogie® JP-2C Clean Channel
56	CALI JP B	Based on Mesa Boogie® JP-2C Crunch Channel
57	CALI JP C	Based on Mesa Boogie® JP-2C Distortion Channel
58	PETHEY SATCH CL	Based on Peavey® JSX Clean Channel
59	PETHEY SATCH CR	Based on Peavey® JSX Crunch Channel
60	PETHEY SATCH UL	Based on Peavey® JSX Ultra Channel
61	CUSTOM 100 Ch1	Based on Custom Audio Amplifiers® PT100 Clean Channel
62	CUSTOM 100 Ch2	Based on Custom Audio Amplifiers® PT100 Drive Channel
63	CUSTOM 100 Ch3	Based on Custom Audio Amplifiers® PT100 Distortion Channel
64	Mr. SMITH CL	Based on PRS® ARCHON Clean Channel
65	Mr. SMITH DS	Based on PRS® ARCHON Distortion Channel
66	TAXIDEA TAXUS A	Based on Suhr® Badger 30 Drive Channel
67	TAXIDEA TAXUS B	Based on Suhr® Badger 30 Distortion Channel
68	ACOUSTIC 1	Acoustic Guitar Simulator 1
69	ACOUSTIC 2	Acoustic Guitar Simulator 2
70	ACOUSTIC	Acoustic Guitar Simulator 3
71~80	3EMPTY	Can import extra amp models

Parameter	Explanation
Gain	Gain level control
Bass	Bass frequency control
Mid	Mid frequency control
Treble	Treble frequency control
Pres	Presence control
MST	Master volume level control

CAB		
MODEL NAME		Description
1	US DLX 112	Based on Fender® 65 Deluxe reverb 112 cabinet
2	US TWN 212	Based on Fender® 65 Twin Reverb 212 cabinet
3	US BASS 410	Based on Fender® 59 Bassman 410 cabinet
4	SONIC 112	Based on Fender® Super Sonic 112 cabinet
5	BLUES 112	Based on Fender® Blues Deluxe 112 cabinet
6	1960 412	Based on Marshall® 1960A 412 cabinet
7	EAGLE P412	Based on ENGL® Pro XXL 412 cabinet
8	EAGLE S412	Based on ENGL® Vintage XXL 412 cabinet
9	MARK 112	Based on MESA/Boogie® Mark 112 cabinet
10	REC 412	Based on MESA/Boogie® Rectifier® STD 412 cabinet
11	CITRUS 412	Based on Orange® PPC412 cabinet
12	CITRUS 212	Based on Orange® PPC212 cabinet
13	SLOW 412	Based on Soldano® SLO 412 cabinet
14	DR.ZEE 112	Based on DR.Z® Maz 112 cabinet
15	DR.ZEE 212	Based on DR.Z® Z-Wreck 212 cabinet
16	JAZZ 212	Based on Roland® JC120 212 cabinet
17	UK 212	Based on VOX® AC30 212 cabinet

CAB

MODEL NAME		Description
18	HWT 412	Based on Hiwatt® AP412 cabinet
19	PV 5050 412	Based on Peavey® 5150 412 cabinet
20	REGAL TONE 110	Based on Tone King® Falcon 110 cabinet
21	TWO STONES 212	Based on Two Rock® 212 cabinet
22	CARDEFF 112	Based on Two Rock® 112 cabinet
23	EV 5050 412	Based on EVH® 5150 412 cabinet
24	HT 412	Based on Blackstar® HTV 412 cabinet
25	GAS STATION 412	Based on Diezel® Hagen 412 cabinet
26	CUSTOM 212	Based on Custom Audio® 212 cabinet
27	US GOLD 412	Based on Friedman® 412 cabinet
28	CALI 412-1	Based on MESA/Boogie® Recto Trad 412 cabinet
29	PETEY 412	Based on Peavey® 6505 412 cabinet
30	Mr. SMITH 112	Based on PRS® Archon 50 Combo 112 cabinet
31	TAXIDEA TAXUS 112	Based on Suhr® 112 cabinet
32	ACOUSTIC 112	112 acoustic guitar cabinet
33-42	EMPTY	For loading 3rd party IRs

Parameter	Explanation
Tube	Tube type selection
Mic	Microphone type selection
Center	Position of microphone relative to the centre of the speaker cone, 0 is in the middle
Distance	Distance of microphone from the speaker. 0 is closest
Sync	Amp model will change according to cab models
Level	Volume level control

NS

MODEL NAME		Description
1	NOISE KILLER	Based on MOOER Micro Noise Killer
2	INTEL REDUCER	Pre-noise gate in front of Drive
3	NOISE GATE	Post-noise gate after Drive

Parameter	Explanation
Threshold	Set the detection level that the Noise gate operates at. Anything below this level will be attenuated when the gate is closed. When a higher level is detected (such as playing your instrument), the noise gate will open and allow sound to pass through
Depth	Intel Reducer is an intelligent background noise suppressor. Depth adjusts the intensity of white noise suppression
Attack	Adjusts the speed at which the noise gate closes and attenuates the sound. 100 is the fastest
Release	Adjusts the speed at which the noise gate opens when you play your instrument. 0 is the fastest

EQ

MODEL NAME		Description
1	MOOER G	5 band graphic EQ for guitar
2	MOOER HM	5 band graphic EQ for BASS guitar
3	MOOER G-6	6 band graphic EQ for Guitar
4	CUSTOM EQ	3 band parametric EQ with adjustable frequencies and $\pm 10\text{Db}$ boost/cut

Parameter	Explanation
Level	Volume level control
Lo-CF	Sets the frequency at which the low cut filter begins to take effect
Hi-CF	Sets the frequency at which the high cut filter begins to take effect

FX Loop

Parameter	Explanation
Send Level	Adjust the volume level from the effects loop send outputs
Return Level	Adjust the recovery level at the effects loop return inputs
Dry / Wet	Progressively adjust the wet/dry mix when in parallel mode. 100% Wet will send 100% of the signal through the FX LOOP just like Serial mode. 100% Dry will bypass the FX LOOP completely
Loop Mode	Choose between serial effects loop and parallel effects loop

DELAY

MODEL NAME	Description
1	DIGITAL Recreates the crystal-clear repeats of the 80's delay units
2	ANALOG Modelled after classic stompbox delays with BB chips
3	REAL Realistic and natural echo
4	TAPE Recreates swirly 70's tape echo
5	MOD Digital Delay with modulated repeats
6	REVERSE Backwards delay
7	PINGPONG Stereo delay
8	DYNAMIC Digital Delay which responds to instrument dynamics
9	DUAL DELAY 2 delays with independent controls

Parameter	Explanation
Feedback	Adjusts the number of delay repeats
Mix	Adjusts the repeats volume level. 0 is total dry, 100 is total wet
Sub-B	Adjusts the delay repeat time in Milliseconds. Sets the delay repeat time in relation to the preset tempo (Tempo Sync On)
Threshold (Dynamic)	Sets the envelope detection level of the dynamic delay

REVERB

MODEL NAME		Description
1	ROOM	Small room reverb
2	HALL	Large room reverb
3	CHURCH	Huge room reverb
4	PLATE	Studio style plate reverb
5	SPRING	Classic spring reverb tank
6	MOD	Reverb with modulation
7	CAVE	Spacious and atmospheric reverb

Parameter	Explanation
Pre Delay	Delay time before the first reflections can be heard
Length	Simulated size of the springs in the spring tank
Level	Volume level control
Decay	Length of the reverb trails
Tone	Tone control

Specifications

Types of Effect :	11
Effects:	Over 180
Presets:	255
Input:	1x1/4" mono jack. Impedance: 1 M Ω
Output:	2x1/4" mono jack, impedance: 600 Ω 2xXLR output, impedance: 600 Ω
AUX IN:	1x1/8" stereo jack, impedance: 10 K Ω
Headset:	1x1/8" stereo jack, impedance: 24 Ω
EXP2:	1x1/4" TRS jack, for 10k~100k impedance expression pedal
SEND:	1x1/4" mono jack, impedance: 600 Ω
RETURN:	1x1/4" mono jack, impedance:1 M Ω
MIDI:	5pin MIDI female port
USB:	1xUSB TYPE-B portSampling rate:44.1kHz
Sampling accuracy:	24bit
Dynamic:	100 dB
Impulse Response	
Format:	wav
Sampling rate:	44.1kHz
Sampling accuracy:	24bit
Sampling point:	2048pts
Power Supply:	9v 1A. Please use the original power supply.
Dimension:	324mmX162mmX60mm
Weight:	1.7kg
Accessories:	USB cable, power supply, quick guide

MOOER
www.moeraudio.com
SHENZHEN MOOER AUDIO CO. LTD
6F, Unit D, Jinghang Building, Luxian 3rd Road,
Bao'an 71 District, Shenzhen, China. 518133